

# COHERENT MULTI-CHANNEL RF SYNTHESIS

## INTRODUCTION

Holzworth Instrumentation is a provider of high-performance, multi-channel RF Synthesizers that are known for ultra low phase noise performance. In addition, these non-PLL based synthesizers have unique phase characteristics, which add a great value to some applications. This white paper addresses some frequently asked questions about multi-channel synthesis and provides insight to the engineering trade-offs that go into a synthesizer design.

## SYNTHESIS ARCHITECTURE COMPARISON

There are many paths to accomplishing a broadband RF synthesis architecture. Depending on the application, there are trade offs to be considered. Table 1 compares primary synthesizer parameters among three common architectures: DDS/Direct Analog (the Holzworth approach), PLL-based, and Analog.

	DDS/Direct Analog (Holzworth architecture)	PLL-based	Direct Analog
Fine frequency resolution	Excellent	Good	Poor
Frequency switching speed	Good to excellent	Poor to good	Excellent
Close to carrier phase noise (< 20-kHz)	Excellent	Depends on implementation	Excellent
Far from carrier phase noise (> 20-kHz)	Good	Excellent	Good
Phase continuous	Yes	No	No
Phase coherence	Yes	Depends	Yes
Phase memory	Future models	No	Yes
Phase glitching	No	Possible	No

**TABLE 1:** *Synthesizer Architecture Comparison*

## DEFINITIONS

Phase continuous, phase coherence, and phase memory are three terms that are often used but not always well understood with respect to RF synthesizers. In addition, these terms are often interchanged. For clarification, these three terms are defined here as used by Holzworth and example waveforms are provided in this paper to illustrate the basic concepts.

**Phase Continuous** - A signal is phase continuous if its phase is a continuous function of time, without any jumps, even in the presence of frequency changes. Holzworth synthesizers are phase continuous for narrow band frequency changes.

**Phase Coherence** - Within the scope of this paper, we define coherence among signals (sharing the same reference frequency) as a relationship whereby an observer can predict the exact state of any signal at any given time based on observing the state of any of these signals at a single point in time. Holzworth multi-channel synthesizers are phase coherent.

**Phase Memory** - A synthesizer with phase memory can switch from one frequency to another, and then back to the first frequency, ending in a phase state as if the synthesizer had never left the original frequency. The Holzworth single and multi-channel synthesis architectures will integrate this capability before the 2011 calendar year.

## PHASE CONTINUOUS

Figure 1 demonstrates the fundamental difference between phase continuous and discontinuous frequency switching. In the first example, the signal is phase continuous, as there are no sudden jumps in amplitude and the new frequencies pick up at the same phase where the old frequencies left off. The jumps in signal level at  $t = 2$  and  $t = 4$  in the 2<sup>nd</sup> example indicate phase discontinuity.

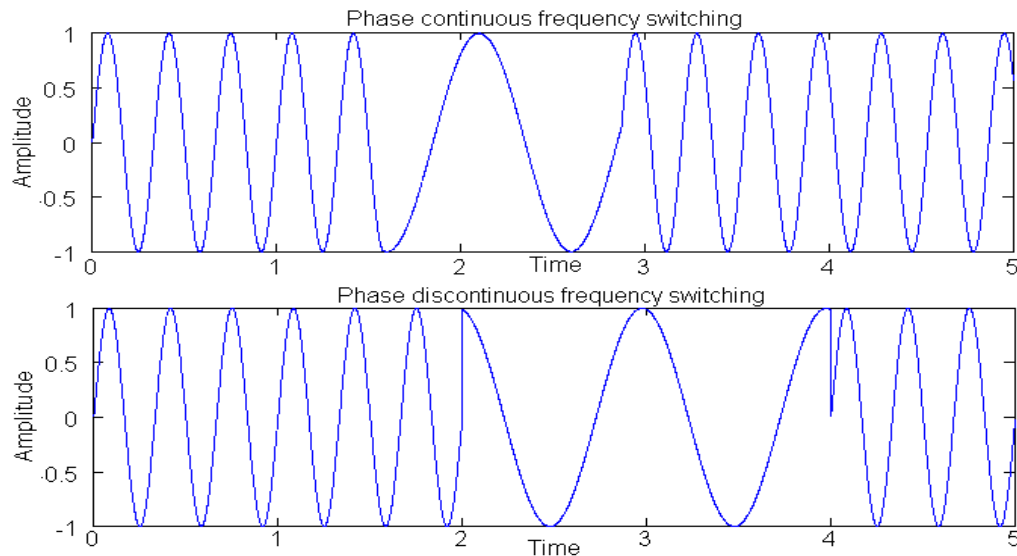

**Figure 1:** Synthesizer phase continuity is an issue of concern for real-time systems.

## PHASE COHERENCE

Ask three different scientists or engineers what coherence means and one will likely receive three different answers. Within the scope of this paper, we will define coherence among signals as a relationship whereby an observer can predict the state of all other signals based on observation of the state of one signal. From a practical standpoint, coherence among RF signals means that once we establish knowledge of the phase relationship among two or more signals via measurement, that relationship will remain intact for as long as the system operates. Measurement of the phase relationships among channels of a Holzworth multi-channel synthesizer allows the user to accurately predict through calculation what those phase relationships will be or were at any time in the future or past.

As an example, consider a dual-channel synthesizer with one channel generating a 1GHz signal and the other channel generating a 2GHz signal. Suppose that upon starting the system, the waveforms are measured with an oscilloscope and the phase control on the synthesizer is adjusted such that the delays between rising edges of the 2GHz signal and 1GHz signal are -75ps and 425ps respectively. If we leave the system and come back a minute, hour, week, or year later and re-measure the rising edge of the 1GHz signal, we will know that the rising edges of the 2GHz signal occurred 75ps before and 425ps after the 1GHz zero-crossing if the synthesizer is phase coherent.

## PHASE MEMORY

A third issue central to frequency switching RF synthesizers is phase memory. Figure 2 shows three examples illustrating phase memory and continuity. The first example has an overlay of two plots to show a synthesizer signal with phase continuity and phase memory. After returning (with continuity) to the original frequency, the phase of the synthesizer signal (blue trace) matches the progression of the original signal (green trace). The second example shows a synthesizer signal (blue trace) that changes frequency and later returns to the original frequency with phase memory, but without phase continuity. The third example, which most closely reflects the behavior of a commercially available DDS circuit, has phase continuity, but after returning to the original frequency, there is a phase shift between the new synthesizer output and time progression of the original synthesizer signal.

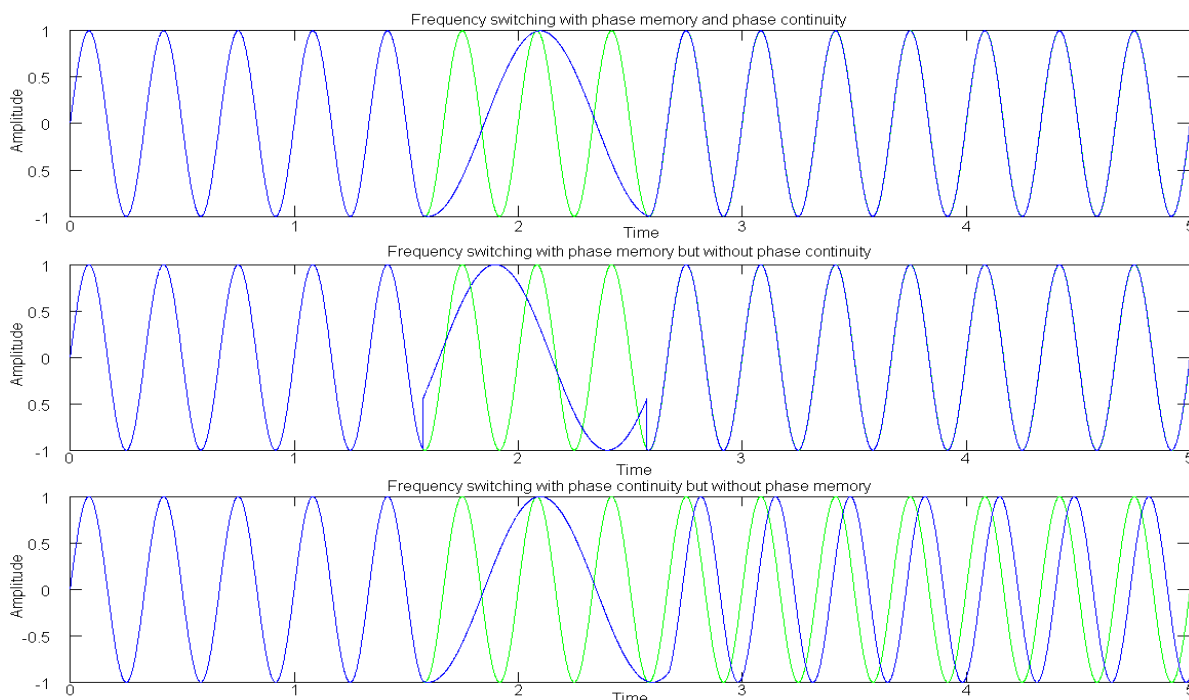
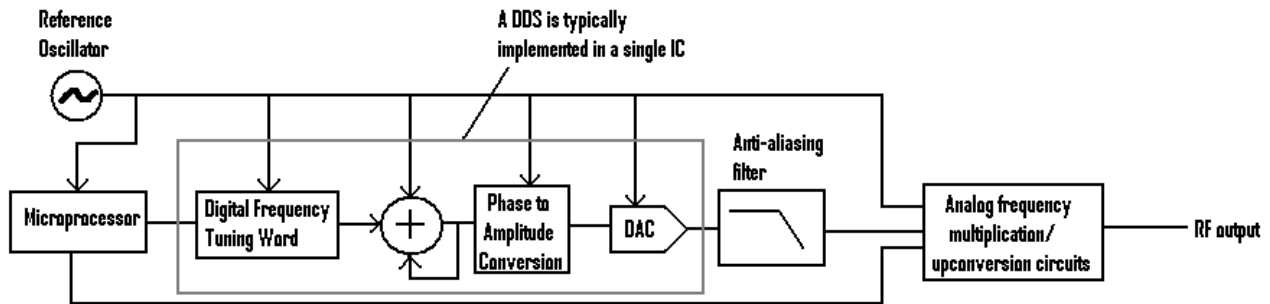

**Figure 2:** *Without synchronization between the analog and digital portions of a DDS-based synthesizer, phase memory and phase continuity are mutually exclusive.*

## HOLZWORTH DDS/DIRECT ANALOG ARCHITECTURE

Holzworth implements coherent multi-channel synthesis by combining a direct digital synthesis (DDS) with direct analog up-conversion architecture with a proprietary reference distribution design. A DDS architecture provides an optimal path to low-noise, fast switching synthesis with extremely fine frequency tuning resolution. The Holzworth direct analog multiplication and up-conversion architecture extends these properties to higher frequencies than are directly available from a DDS.

Figure 3 shows a simplified hybrid DDS-direct analog synthesizer architecture. At each cycle of the clock, the programmable FTW (Frequency Tuning Word) is added to the existing value in the digital phase accumulator. At the same time, the existing phase value is converted to a digital magnitude in the phase to amplitude conversion block, typically implemented with either a ROM-based look-up table or a DSP sinusoid solver algorithm. Also at the same time, the existing digital magnitude value is clocked into a DAC which generates an analog waveform. An anti-aliasing filter, coupled with analog frequency multiplication and up-conversion circuitry extends the bandwidth of the synthesizer beyond what is achievable directly from the DDS.



**Figure 3:** The Holzworth Instrumentation DDS-based synthesizer architecture combines fine frequency tuning resolution with the advantages of direct analog architectures.

### TRADITIONAL DIRECT ANALOG ARCHITECTURE

Figure 4 shows a traditional analog synthesizer architecture that uses frequency multiplication, division, selection filters, frequency mixers, and image filters to produce the desired analog frequency. An increase in bandwidth or tuning resolution results in higher complexity filters for a given spur level specification to reject images after the frequency mixing stages.

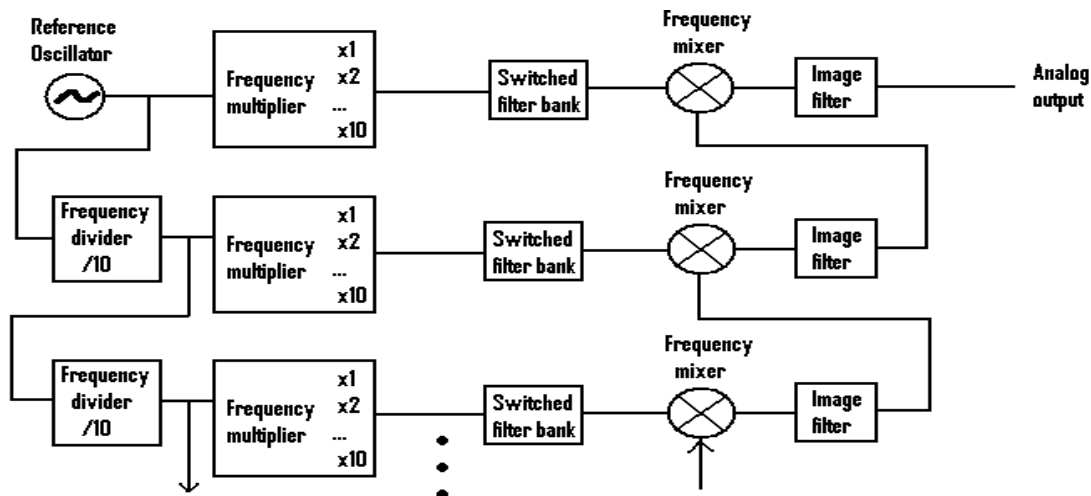

**Figure 4:** A traditional analog synthesis architecture requires significant hardware complexity in order to achieve wide bandwidths and fine frequency tuning resolution.

## HOLZWORTH MULTI-CHANNEL ARCHITECTURE

When two DDS channels are driven by coherent clocks and a phase relationship between the analog outputs is established, then knowledge of one channel's state allows one to predict, with certainty, what the other channel's analog output state is. The output frequency of a DDS is a function of the digital clock frequency and the frequency tuning word. The relationship is shown in equation 1.

$$\text{Equation 1: } f_{\text{analog}} = f_{\text{clk}} \cdot \frac{FTW}{2^N}$$

In Equation 1, N is the number of bits in the digital phase accumulator. The frequency tuning resolution of a DDS can be calculated by inserting a value of 1 for the FTW and solving Equation 1. For example, with a 100MHz clock and a 32-bit accumulator, the frequency tuning resolution is approximately 23mHz. It should be noted that analog frequency multiplication circuitry will degrade the frequency resolution achievable from a full synthesizer system.

A significant engineering challenge for DDS-based synthesizer implementation relates to absolute frequency accuracy. Suppose a DDS-based synthesizer is clocked from a lab "golden" standard 10MHz external reference, and the user wants to generate a 100kHz signal. With a 16-bit phase accumulator and a 10MHz clock, the resulting ideal FTW is 655.36. However, the FTWs for commercially available DDS ICs are programmed as integer values. Programming FTW values of 655 or 656 results in analog output frequencies of 99.945068-kHz and 100.097656-kHz respectively. With more bits in the digital phase accumulator, the magnitude of frequency errors is substantially reduced compared to the 16-bit example. The example is meant to illustrate the difficulty associated with generating an output that is an exact integer multiple of the reference or clock frequency.

### HOLZWORTH INTELLECTUAL PROPERTY

Holzworth offers an architecture option (OPT-INTGR) using techniques that have been specifically developed for correcting the FTW rounding error. Using a combination of analog and digital feedback, Holzworth synthesizers can generate output frequencies with exact integer frequency relationships to each other while maintaining zero phase drift error with respect to an external reference frequency.

Another complication associated with a DDS-based architecture revolves around phase continuity and phase memory during frequency switching. Referring back to the examples of phase continuous and discontinuous frequency switching in Figure 1, helps to illustrate this point. In a DDS-based synthesizer, if the FTW is programmed to a new value then the analog output of the DDS will be phase continuous. If the FTW is programmed to a new value and the digital phase accumulator is simultaneously cleared or returned to a preset value, then the analog output will be phase discontinuous unless the FTW programming and phase accumulator update are synchronized with a specific analog output phase.

## NARROW BAND FREQUENCY SWITCHING

Figure 5 shows an oscilloscope screen capture of a Holzworth synthesizer transitioning from 10MHz to 110MHz. The transition is phase continuous, like the first example waveform in Figure 1. The frequency change in a DDS-based synthesizer is based on reprogramming the FTW, so while there is digital latency and propagation delay through the analog circuitry, the frequency change at the DDS analog output is instantaneous. Upon changing frequencies, there is some ripple in the RF amplitude which is due to the frequency responses of the analog filters and automatic level control circuitry that sits between the DDS analog output and the synthesizer channel output.

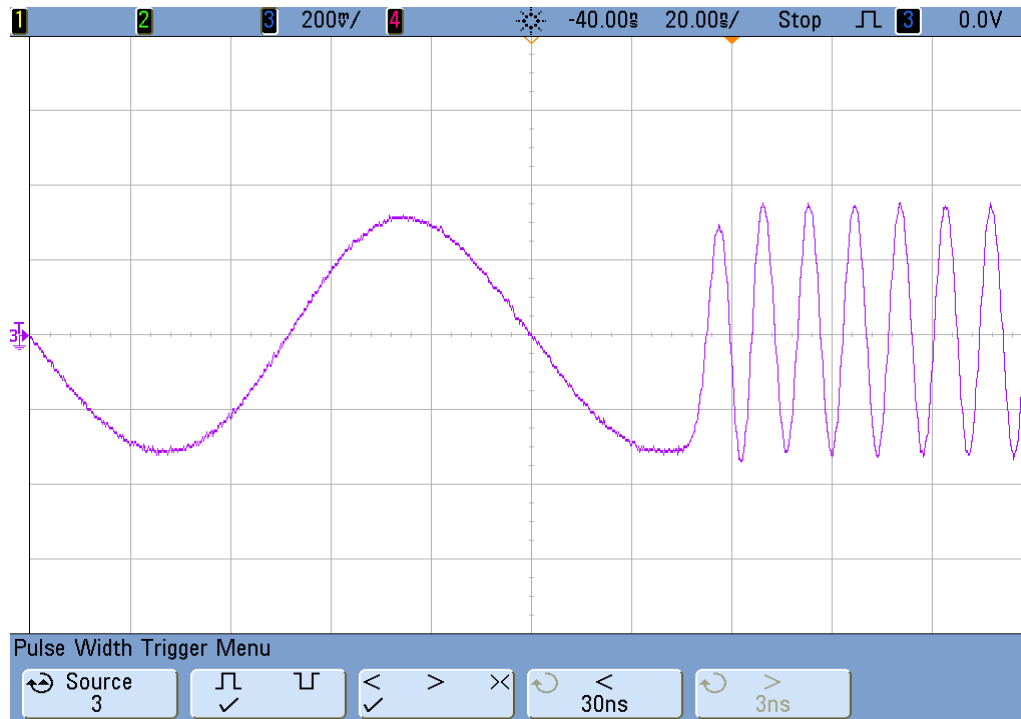

**Figure 5:** *The Holzworth DDS-based synthesizer is phase continuous for narrow-band frequency transitions.*

## WIDE BAND FREQUENCY SWITCHING

Figure 6 shows a screen shot of a Holzworth synthesizer transitioning between different analog frequency bands. During a band-to-band transition, the RF output drops out momentarily. Holzworth synthesizers are specified to have switching speeds faster than 50 $\mu$ Sec. Measuring the delay between the end of the first band envelope and the start of the 2<sup>nd</sup> band envelope, we see this transition occurs in about 20 $\mu$ Sec. Upon entering the new frequency band, the effect of automatic level control circuitry is more obvious than in a same-band frequency update. The automatic level control feedback loop can take up to 1mSec to settle, so while the output frequency is valid as soon as the RF signal turns on, the amplitude can take much longer to stabilize.

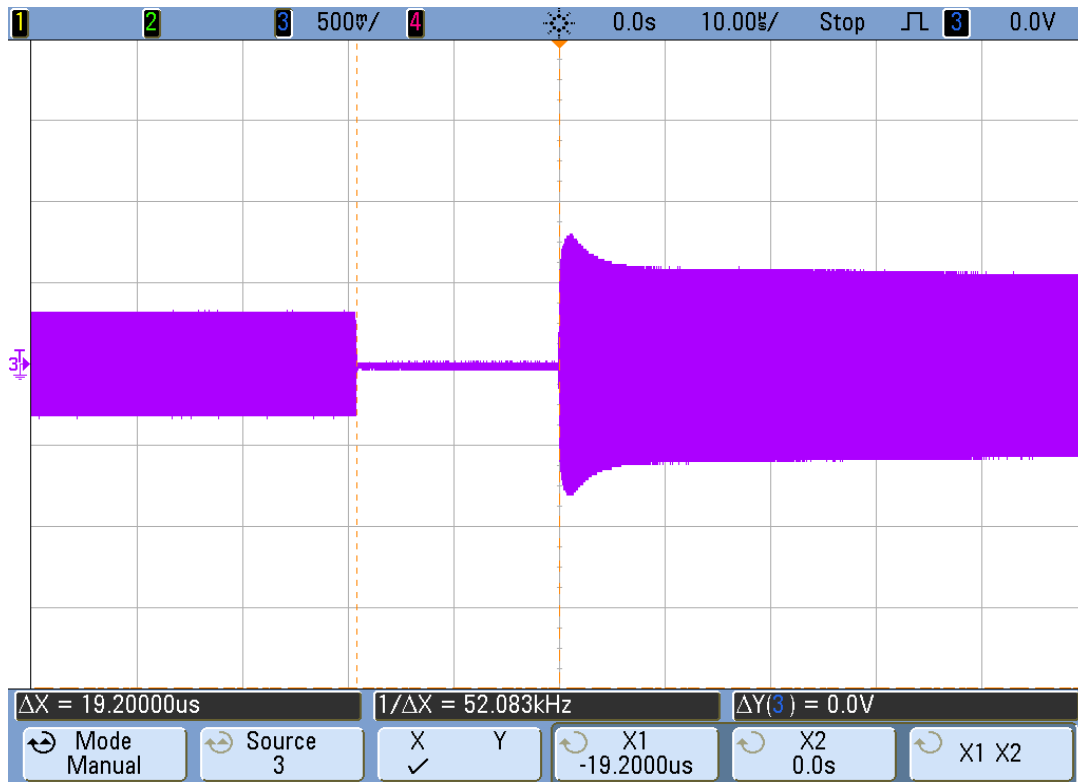

**Figure 6:** When transitioning between analog frequency bands, the RF output from a Holzworth synthesizer drops out momentarily as shown in this scope capture of the RF amplitude envelope.

## CONCLUSION

In applications where phase continuity, phase coherency and phase memory are absolutely critical, the DDS/Direct Analog approach to RF synthesis is optimal for providing both absolute and relative accuracy and elimination of frequency errors. In addition, the Holzworth DDS/Direct Analog architecture can support very fast switching speeds (<1 $\mu$ Sec from digital frequency update command to valid analog output).

Holzworth engineering innovates new technologies that push the envelope of what is possible in high-performance RF synthesis, offering a wide range of COTS and application specific solutions for demanding applications.

Authored by:  
KARL ERICKSON  
Sr. Hardware Engineer  
Holzworth Instrumentation